

ANALYSIS, OPTIMIZATION, AND DEVELOPMENT OF A SPECIALIZED PASSIVE SHOCK ISOLATION SYSTEM FOR HIGH SPEED PLANING BOAT SEATS

Alan R. Klembczyk, Chief Engineer
Taylor Devices, Inc.
North Tonawanda, NY 14120-0748
716-694-0800

Michael W. Mosher, Senior Engineer, Structures
Tayco Developments, Inc.
North Tonawanda, NY 14120-0748
716-684-0800

The Mk V Special Operations Craft (SOC) is used to carry Special Operations Forces (SOF) into and out of combat operations. Previous experience and research has demonstrated that during operation, particularly during extended training missions, the passengers and crew have reported numerous cases of musculoskeletal injuries from operation in high sea states. Analytical research is presented here that employs guidelines as set forth in previous research performed for the U.S. Army Aeromedical Research Laboratory, Fort Rucker, AL. This previous research is used for quantifying human exposure to multiple shock inputs and in part is currently being proposed as an International Standard as DRAFT ISO/DIS 2631-5. For the current research, a parametric optimization study was conducted that evaluated potential suspension system concepts utilizing actual field generated forcing functions. As a result, a highly specialized, non-linear, passive shock isolation system was developed. This isolation system has been integrated within the suspended seats of the Mk V SOC. Initial sea trial testing and deployment of the isolation system has resulted in positive operator feedback that correlated well with the actual field measurements, thereby validating the predictions of the analytical efforts.

INTRODUCTION

Over the past several years, increasing attention has been given to recurring problems encountered by the operators and crew of Special Warfare high speed planing boats with respect to a high incidence of self-reported musculoskeletal injuries. Many of these reported injuries have been the result of the high levels of shock input to the Special Operations Forces (SOF) as experienced during operation of Special Operations Craft (SOC) in moderate to heavy sea states while in their seats. Previous research has verified and documented the statistical evidence, and has also called for a concise, cost-effective, and reliable solution to reduce the risk of injury.

The research and development presented here demonstrates a solution for use on the U.S. Navy Mk V SOC. This particular SOC is an aluminium hull boat, 81 feet in length, powered by twin 2285 HP diesel engines and is capable of a wide range of mission assignments. The Mk V is equipped with multiple seating accommodations for the crew and passengers. The resulting solution to minimizing the risk of injury involves the use of a suspended boat seat, equipped with a specialized shock isolator with optimized output properties as described herein.

In the year 2000, the Naval Health Research Center in San Diego, CA published a Technical Report entitled "A Survey of Self-Reported Injuries Among Special Boat Operators" [1]. This Report quantified the statistical risk and the resulting high rate of injury that SOF reported during operation of SOC, including the Mk V. To summarize the findings of the survey, 64.9% of operators reported at least one injury. Some respondents reported up to three injury events. The types of injuries reported include sprains/strains, disc problems, trauma, various dislocations, chronic pain and stress fractures, among others. These injuries resulted in a high hospitalization rate. In fact, within the U.S. Navy, only construction-men, seamen, firemen, and airmen had higher hospitalization rates than those surveyed, as stated in the Report. The Report concludes that "methods to reduce the injury risk must be identified and implemented."

In 2001, a paper was published for the Shock and Vibration Information Analysis Center (SAVIAC) entitled “Shock Mitigation for High Speed Planing Boats” by Dr. Ronald Peterson [2]. This publication identified the aforementioned problem, described a suggested analytical method and model for analyzing and reducing the shock input to the SOF, and also suggested potential shock mitigation concepts. The method and model outlined within the publication references the Standard ISO 2631, and describes the Dynamic Response Index (DRI) as first being developed to characterize vertical shocks and the potential for spinal injury from aircraft ejection seats. The DRI is fully defined in a publication entitled “Development of a Standard for the Health Hazard Assessment of Mechanical Shock and Repeated Impact in Army Vehicles Phase 5” [3]. The research outlined in that publication by the U.S. Army Aeromedical Research Laboratory, Fort Rucker, Alabama, has contributed to a new publication currently being proposed as a new ISO Standard, now referred to as DRAFT ISO/DIS 2631-5 [4]. In brief, the DRI is effectively a measure of the peak acceleration realized by a human, modeled as a spring, mass, and damper with specific and well-defined parameters, when subjected to a known forcing function. These parameters will be defined within this paper.

Defined within DRAFT ISO/DIS 2631-5, is another variable used to characterize the shock input to the human model. This variable, Se , is basically a summation of the equivalent static compressive stress realized by the human model. The significance of this variable is that it is a cumulative measure of stress over a normalized period of time.

For the purposes of the research presented here, the optimized solution is defined as that solution that minimizes both the DRI and Se , in an attempt to reduce both the maximum and cumulative effects of several actual measured forcing functions (acceleration vs. time) of the Mk V SOC when used as inputs to the human model. These forcing functions were measured previously during sea tests on the Mk V in moderate to heavy sea states.

The results of the following research have defined a shock isolation system for integration into the Mk V SOC. Following the analytical effort, actual isolation systems were fabricated for sea trial tests, that would seek to validate the analytical effort and provide a viable solution to the recurring injury problem.

ISOLATION SYSTEM CONCEPT

Other previous research on the current subject includes the consideration of several shock mitigation concepts. These include concepts that are related to the seat, the hull design, the deck, protective gear, etc. A fully active shock isolation system has also been considered. However, the Special Operations Forces desired a low risk, highly robust, reliable, and cost-effective solution for the Mk V SOC that would minimize any impositions on the mobility of the operators and crew. An isolation system that required a high system travel, or stroke, was not desired since it would affect the ability of the operators to read the instrumentation and to maintain a visible view of the horizon. A suspended seat equipped with a relatively low displacement passive shock isolator does not have these disadvantages. Additionally, a passive system requires no external power source, requires no maintenance, is lightweight, and is easily integrated into the existing seat design.

In order to analyze and derive an optimal solution for defining the shock isolation system output parameters, an accurate input to the suspended seat is required. During previous sea-trial tests of the Mk V SOC, several forcing functions were measured and recorded. These forcing functions are believed to be representative of typical inputs that the SOF will experience during operation and training missions in moderate to heavy sea states. In fact, one recorded forcing function includes a singular shock event that was so severe that the engines of the Mk V cut out.

Also required for an optimization study are the potential attributes and output parameter options available for a specialized shock isolation system. Many isolation systems have previously been developed for various types of applications. These include isolation systems for the vibration and shock protection of surface ship-board equipment, systems and structures on board submarines, space based systems, military vehicles, airborne vehicles, buildings and bridges, and many others. It is essential that the analyst be equipped with a full database of isolation system attributes that have been proven effective and reliable in a wide variety of shock isolation applications in the past.

Isolation systems generally consist of a spring component and an energy absorbing component. The spring component provides the system reset capability and provides for a specific natural frequency of the isolated mass. The spring applies force to the isolated mass as a function of position only. This function can vary in either a linear or non-linear manner with respect to system deflection. The energy absorbing component provides the necessary damping element and can provide force to the isolated mass as a function of input velocity, position, or a combination of both. Additionally, the damping component can be responsive to position, velocity, acceleration, or higher derivatives. Thus, the damping element can quickly change or adapt its output function during the shock event based on a combination of the input parameters. The damping element can also vary output in either a linear or non-linear manner. The result is a specialized shock isolation system, capable of providing a high level of isolation, with all the advantages of a passive system, yet retaining the advantages of an active system. The analytical efforts presented here have taken advantage of all the possible attributes of this type of passive system.

ANALYTICAL MODEL DESCRIPTION

The deck-seat-spine in the vertical direction is idealized as a two degree-of-freedom (2-DOF) model as follows:

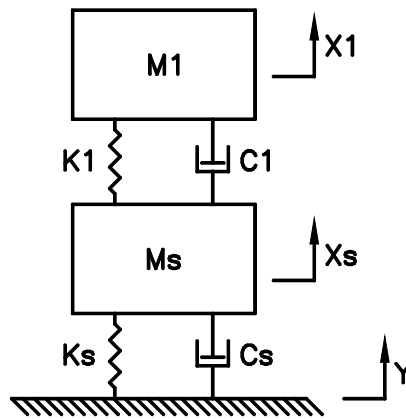

Figure 1. 2-DOF Model of Seat Pan and Operator

where:

M_1 :	Operator Effective Mass
M_s :	Suspended Seat Pan Mass
X_1 :	Operator Absolute Displacement
X_s :	Seat Pan Absolute Displacement
K_1 :	Operator Spine Spring Constant
K_s :	Shock Isolator Spring Constant
C_1 :	Operator Damping Constant
C_s :	Shock Isolator Damping Constant

and where the deck is idealized as an infinite inertial mass (i.e., the seat pan and operator subsystem in no way affects the acceleration input y). The human spine-seat pan model is non-linear as described in DRAFT ISO/DIS 2631-5 for vertical type inputs, and accounts for inputs in all three orthogonal axes (the two horizontal axes to the spine as well). However, since the shock isolator-seat system will only provide isolation in the vertical direction, the other two axes are ignored for these analytical purposes. This draft standard uses some known acceleration versus time data (in this case from an actual recorded sea trial test) and sends it through a pre-trained neural network to determine such parameters as the maximum spine compressive forces (accelerations) and the cumulative damage indexes, DRI and Se respectively. However, it does not lend itself well to interactive models for predictive purposes where, in this instance, a shock isolator was to be designed that would decrease the reaction of the spine-human torso to acceleration deck inputs (since the neural network requires a previous acceleration-time history). After

discussions with bio-engineering experts from the University of Virginia, the spring function and the velocity dependent damping function of the human torso model were assumed to be approximately linear for modeling purposes. As described in the research for Fort Rucker [3], the human torso can be approximated as a subsystem with a natural frequency of 8.42 Hz and a critical damping ratio of 0.224. From this model, the DRI is calculated from the maximum absolute relative motion between the spine and the seat pan directly as follows:

$$DRI = \frac{\omega_n^2 * |x_s - x_l|}{g} \quad (1)$$

where

ω_n = the undamped natural frequency of the human mass

$|x_s - x_l|$ = the relative displacement as shown in Figure 1

g = gravitational constant

The variable Se (the equivalent, cumulative static compressive stress in MPa over a ten hour duration in this case), although not as direct, is calculated by capturing the simulated acceleration-time history of the seat pan in m/s^2 , and then directing it through a developed code for its post-processing calculation. This is represented by the following equation:

$$Se = [\Sigma(m D)^6]^{1/6} \quad (2)$$

where

m = a normalized compressive stress factor ((MPa) / m/sec^2)

D = acceleration dose (m/sec^2)

Models of the system were developed by Taylor Devices, Inc. using TSIS (Taylor Shock Isolation Simulation Program). This provided a double check on the analytical results. All predictive analyses were performed by setting the preload of the isolator (which is adjustable) such that it compressed the isolator one inch from its full extension stops regardless of the weight of the operator on the seat. This sets the initial available isolator stroke to a constant value.

The spring rate that was analyzed with varying degrees of linearity had an initial value determined from positive operator feedback from previous boat seat trials. This value was determined to feel comfortable for personnel under low sea states. A lower spring rate resulted in negative comments from the operators (although this could lead to slightly lower DRI and Se criterion values) and a stiffer value would transmit more vibration energy to the riders under low sea states, and could therefore lead to larger values in Se in the analyses. A secondary spring rate was simulated as being available later in the stroke to add more energy capacity to the shock isolator under severe sea state conditions. The advantages of this deflection-dependent change in spring rate became apparent when comparing the realized improvement over the full range of forcing functions. The softer spring rate near the beginning of stroke would help to maintain comfort at low sea states, and a stiffer spring rate would provide additional energy absorbing capability when required only for the more severe sea states.

OPTIMIZATION STUDY

An optimization study was performed to design a seat shock isolator that would minimize the ride criterion set forth by the previous research. These criteria were the Se values and the DRI as defined above. This study was initially performed using the existing constraints imposed on the available stroke of the isolation system that would enable the system to be easily incorporated into the existing seat design. This provided for a system travel between 6.5 and 7.0 inches.

The study started with a data set of forcing functions that were provided from sea trial tests of the Mk V SOC occurring in January of 2002. A sample of one of these forcing functions is shown in Figure 2.

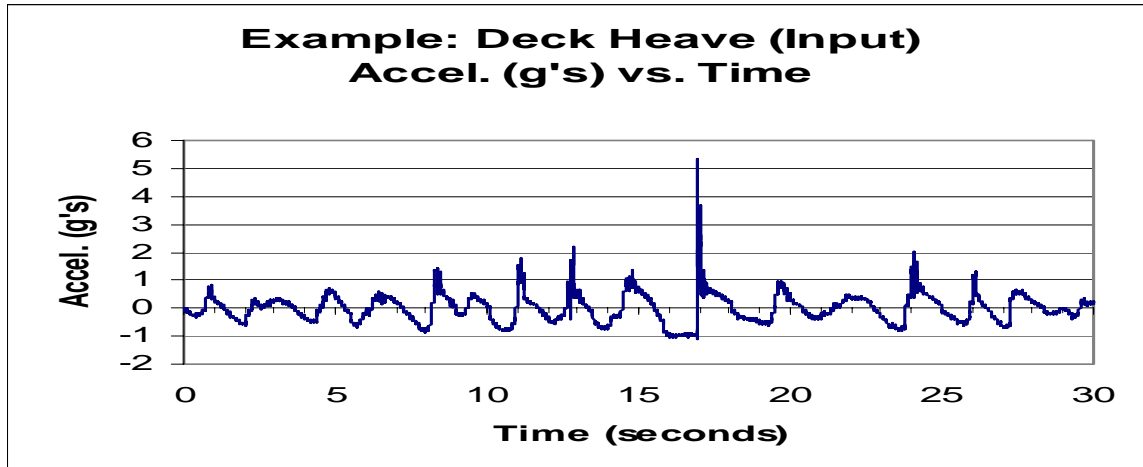

Figure 2. Example of Deck Heave Data used as Input to Analytical Model

Isolator parameters were developed that resulted in optimal response to these sea states. More forcing functions were later obtained that were much more severe than those initially used in the study. The lessons learned from the initial study were then applied to the new data set.

Analytical optimization was performed by setting up cost functions representative of the DRI and/or Se values, and minimizing these cost functions. Recall that the DRI is indicative of the most severe single shock event seen by the operator while the Se is more indicative of the ride quality. However, the Se can be heavily influenced by the worst case shock event analyzed for the small time duration events (when compared to 25 years' lifetime). Since the resulting shock isolator in this study was highly non-linear, brute force optimization occurred later downstream in the analytical efforts. This was due to the fact that computation minimization algorithms were converging to local minimas, and realistic design constraints were being imposed.

The study began with a simple linear-spring model, where computational minimization led to improved results, holding the spring rate at a constant value. After the results were obtained, the analysis used a non-linear damping exponent, where it was found that on an individual input stream basis, significant improvement could be achieved in the performance criteria. However, over the entire range of forcing functions, the non-linear exponent achieved similar results as the linear damping exponent. Attention was then turned to the effects of the damping function in the extension mode. It was desired to resist the spring force enough not to propel the seat into the extension stops, but not so slow as to not being able to follow the periodic wave motion and thus "ratchet" down the available stroke of the isolation system. Studies found that throughout the range of forcing functions, the optimized extension damping level would always allow the isolation system to reset quick enough to react to the next event.

A variable damping coefficient that was velocity dependent (i.e., an adaptive velocity sensing damping function) yielded very positive results when the entire field of forcing functions was analyzed. This was found to have the ability to minimize the Se in the moderate sea state conditions, yet provide enough energy capacity to avoid bottoming the isolation system under the most severe sea state conditions. Indeed, the isolation system did not bottom out when subjected to the forcing function that caused the twin engines to cut out. A study on a multi-linear spring rate was found to offer more energy capacity as well, and was eventually incorporated into the design.

The final study was on the possible weight variability of the operators. The study would result in a shock isolator that did not bottom with the heaviest specified operator on the seat, yet would not transmit a severe shock to the lightest specified operator. It was found that although the DRI and Se increased for the lightest specified operator, it was by a very small percentage and considered negligible.

Studies were performed on a longer stroke shock isolator to determine what effect more available system travel would have on the shock mitigation properties. One of the interesting phenomenon that occurred was that in order to reduce the Se and DRI for the longer stroke isolators, the spring rates would need to decrease substantially. This occurred because otherwise, the spring would tend to dominate the output and negatively affect the performance criterion to the point where the criterion would be higher than that of the original isolator stroke studied. In shorter stroke isolators, the level of damping had a greater effect on the Se and DRI. In fact, the spring rate would need to be lowered to values below that which the operators had negative comments about in previous sea trial testing. The issue of visibility over the horizon line of the boat and human comfort from a ride suspension frequency point of view is also a concern.

A comparison of the 6.5 inch stroke optimized isolator against a rigidly mounted seat are shown in Table 1.

Input	DRI			Se (MPa)		
	Isolated	Rigid	% Red.	Isolated	Rigid	% Red.
Input File #1	3.09	9.70	68.1	2.91	11.9	75.5
Input File #2	2.45	2.89	15.2	2.78	2.84	2.10
Input File #3	3.04	3.46	12.1	3.44	4.20	18.1
Input File #4	2.88	3.27	11.9	3.24	3.96	18.2
Input File #5	8.76	10.9	19.5	7.61	9.26	17.8
Input File #6	4.86	5.02	3.2	4.69	8.60	45.5

Table 1. Optimized Alpha Isolator vs. Rigid Mount

Input Files #1 through #4 shown in Table 1 are representative of moderate sea states. Input File #6 is moderate to high, and Input File #5 is the input in which the boat engines cut out. What is obvious is the large reduction that the simulated optimized isolator has on both the DRI and the Se.

Table 2 presents a comparison of analyzed isolators with varying stroke against a rigidly mounted seat for the DRI criterion. Table 3 presents the results for the Se criterion.

Input	6.5 Inch Stroke % Reduction	7.5 Inch Stroke % Reduction	10 Inch Stroke % Reduction
Input File #1	68.1	67.9	68.0
Input File #2	15.2	16.6	20.8
Input File #3	21.1	12.1	18.8
Input File #4	11.9	11.9	16.2
Input File #5	19.5	22.2	28.0
Input File #6	3.2	8.0	16.5

Table 2. DRI Comparison of Isolators With Varying Stroke Lengths

Input	6.5 Inch Stroke % Reduction	7.5 Inch Stroke % Reduction	10 Inch Stroke % Reduction
Input File #1	75.5	75.5	75.8
Input File #2	2.1	1.4	8.1
Input File #3	18.1	18.1	22.1
Input File #4	18.2	18.1	23.5
Input File #5	17.8	20.2	28.4
Input File #6	45.5	41.2	48.7

Table 3. Se Comparison of Isolators With Varying Stroke Lengths

The optimization procedure included an effort to reduce the performance criteria to the most severe forcing functions labeled in the Tables as Input File #5. There is a marginal improvement realized from greater isolator stroke length for the more moderate sea states, and a much larger improvement for the most severe case. But the criteria minimized does not take into account the natural frequency effects on human comfort (i.e., nausea) and thus are not reflected in the analytical results.

Based on the comparative results of the optimization study, it was determined that an isolation system with 6.5 inches of available stroke followed by a short stroke snubber made a significant improvement. Adding isolator travel beyond 6.5 inches offered diminishing improvements. In summary, the study resulted in an isolator with non-linear and bi-directional damping functions, velocity sensing valves to provide an adaptive response to the input, a quadri-linear spring rate, and an adjustable spring preload feature. The importance of these features is that the isolator is able to alter, or adapt, its output characteristics to the level of the input, so that the isolator will minimize the shock to the operator over the entire range of input possibilities. This is especially critical to minimizing the cumulative effects of the input, however small, while maintaining enough energy absorbing capacity to prevent hard bottoming from the most severe conditions.

It was then decided to design and manufacture four individual isolators with varying output characteristics in an effort to bracket the targeted solution. These four isolators were designated as Alpha, Bravo, Charlie, and Delta. The optimized isolator as described above was designated as the Alpha isolator. The Bravo isolator had a higher damping output function and altered velocity sensing valves to provide a much higher energy absorbing capability. The Charlie isolator was similar to the Alpha isolator, but had faster reacting valving to provide a slightly higher energy capacity in heavy sea states. The Delta isolator had a lower damping output and different valving than the Alpha Isolator, that would create a softer feeling ride in low to moderate sea states, but would have reduced energy absorbing capability in the higher sea states.

Prior to deploying the individual isolators for sea trial testing on the Mk V seat, a series of component tests were performed in order to verify the required output parameters and characteristics as defined in the analysis. These tests were performed across the entire velocity and deflection range of the suspended seat. Additionally, a computer controlled hydraulic servo actuator system was used to cycle the isolators through an actual forcing function input file provided from the previous sea trial tests.

THE Mk V SOC SEAT WITH ISOLATION SYSTEM

The Mk V SOC seat itself is a current design of STIDD Systems, Inc. of Greenport, New York. Previous efforts to provide some level of isolation to the seat have resulted in the current design that consists of a seat base rigidly mounted to the deck and a suspended seat portion guided by twin rails with linear ball bushing bearings. The Shock Isolator, designed and manufactured by Taylor Devices, Inc., provides the required spring and energy absorption, along with the adaptive attributes as dictated by the analysis outlined above. Figure 3 and Figure 4 illustrate the suspended seat.



Figure 3. Sub-Assembly of Suspended Seat With Shock Isolator



Figure 4. Rear View of Suspended Seat With Removable Isolator Cover

INITIAL RESULTS OF SEA TRIAL TESTS

In January 2003, a single Mk V SOC (Boat A) was equipped with six new isolated seats. The front row of seats was outfitted with one of each shock isolator, designated as Alpha (A), Bravo (B), Charlie (C), and Delta (D). Two seats in the second row were outfitted with a B and C isolator. These new seats were then evaluated by the Naval Special Warfare Group Four (NSWG4), Special Boat Team 20, Detachment 3 in a transit from Little Creek, Virginia to King's Bay, Georgia. This distance is approximately 650 miles. A planned stop was made at Cape Fear, North Carolina. A series of tests was performed during the transit in order to capture the relative performance over a range of headings with respect to the seaway direction, and over a range of craft speeds. Another Mk V SOC (Boat B) followed, equipped with only the original rigid, non-isolated seats. Additional tests have since been conducted both in the Atlantic Ocean and the Pacific Ocean, by different Special Boat Teams, in different Mk V SOC. These tests were run in seas running as high as ten feet.

At the time of the initial tests performed between Little Creek and King's Bay, a direct parametric measurement comparison was not made between the isolated and non-isolated seats. However, on-going tests are providing for a more direct comparison and will attempt to quantitatively assess the improvements realized by the addition of the shock isolators. In addition, the data that will be recorded during future testing will be run through the appropriate algorithms and the resultant values of both the DRI and the Se will be determined.

The tests performed in January 2003 included accelerometer readings at various locations of both the seats and the operators. Additionally, observations were made from video recordings. Questionnaires provided direct feedback from the operators. Initial comments from the operators riding on the isolated seats have been extremely positive. An assessment of the improvement in comfort level can be summarized by the following excerpts made by various operators during the different tests conducted thus far:

“The new seats are a great success. It has allowed the crew to push the boat faster than the boat can actually handle.”

“At first, we instinctively braced for the impacts, but as we got used to the seats, we relaxed and let the shock absorbers do their job.”

“The trail boat (Boat B) reported seeing (Boat A) completely airborne, yet the crew of (Boat A) was quite comfortable.”

“The operational impact of the new seats is hard to overstate.”

“We were trying to beat the building storm, but lost the race because (Boat B, without isolated seats) could not maintain the necessary speed. Again, the new seats would have cut a day off our transit time.”

“During these long transits we will save significant time while preventing crew injury and fatigue with the new seats.”

“These seats will both spare SWCC (Special Warfare Combatant Crewmen) from many injuries, and expand our tactical performance by allowing us to operate faster for longer periods of time.”

“All four models are a marked improvement over the standard seats.”

“Seats handled beautifully. There was a noticeable difference between riding in the shock seats during high seas versus riding in the non-shock mounted seats.”

“They ride like a Caddy.”

Other comments were gathered during the tests in order to determine the relative performance of the different types of isolators. Some operators preferred the Alpha isolator, while others preferred the Charlie isolator. Recall that the Alpha isolator was the analytically optimized isolator and that Charlie is a slight variant of Alpha. The softest isolator, Delta, occasionally bottomed out during extreme hits (as predicted by the analysis) and was therefore stated to be less comfortable, although some commented that this isolator bottomed without pain or discomfort. It was further stated that the stiffest isolator, Bravo, did not bottom out but was too firm and was therefore much less comfortable than the Alpha isolator. These comments demonstrate that the Alpha and Charlie isolators provide what feels most comfortable to the operators. Additionally, the comments correlate well with the analytical predictions in terms of both maximum isolator travel, and the degree of operator comfort as predicted by the criterion set forth in the aforementioned previous research.

Additional evaluation is continuing to more accurately define the improvement in terms of maximum acceleration to the operator, rise time of the acceleration dose, and the reduction of cumulative statistical injury to the occupants of the Mk V SOC.

CONCLUSIONS

Previous research has documented statistical evidence and has called for solutions to the ongoing injury risk to Special Operations Forces when operating Special Operations Craft especially during operation in moderate to heavy sea states. It has been desired by the U.S. Naval Special Warfare Command, and the U.S. Special Operations Command to identify, develop and integrate a concise, cost-effective, and reliable solution to reduce the risk of injury.

An analytical method has been established to optimize a shock isolation system for use in the U.S. Navy Mk V SOC by using criteria set forth in previous publications that have sought to quantify and assess the human health risk resulting from mechanical shock. These criteria address the health risk associated with singular events and cumulative injury from multiple events. The analytical method has defined an optimized shock isolator that has drawn its special attributes from proven technology.

The specialized shock isolator has been successfully designed, manufactured, and integrated within the Mk V SOC. Component level tests of the isolator itself have verified the ability of the isolator to provide the specialized attributes with the particular output parameters as dictated by the analysis. A computer controlled hydraulic servo actuator system has been used to cycle the isolator through an actual recorded forcing function that has verified the ability of the isolator to respond properly to the typical input environment associated with the Mk V SOC.

Tests performed in both the Atlantic and the Pacific Oceans have resulted in positive operator feedback when comparing isolated seats versus non-isolated seats. The new seats and their isolation systems have allowed the operators to push the boats significantly faster and to operate for longer periods of time than boats without the isolation systems.

Comments from the operators have correlated well with the analytical predictions when comparing isolators with differing output parameters. This correlation suggests that the method outlined in previous research with respect to minimizing both maximum acceleration (DRI) from singular events and cumulative injury predictions from multiple events over a normalized period of time (Se) have been shown to offer a significant benefit. On-going research is being performed that will attempt to more accurately quantify these criteria against actual measured data from tests at sea during periods of moderate to heavy sea states.

The resulting seats with the new isolation system for use on the Mk V SOC have shown significant improvement over the existing seats with respect to reported operator comfort level. It is anticipated that this improvement will allow the Mk V Special Boat Teams to complete their operational and training missions with far fewer injuries while at the same time gaining significant tactical advantages.

REFERENCES

1. Ensign, W., Hodgdon, J., Prusaczyk, W., Ahlers, S., Shapiro, D., Lipton, M., 2000, "A Survey of Self-Reported Injuries Among Special Boat Operators," NHRC TR 00-48, Naval Health Research Center, San Diego.
2. Peterson, R., "Shock Mitigation for High Speed Planing Boats," 72nd Shock and Vibration Symposium, Nov. 12-16, 2001.
3. Morrison, J., Robinson, D., Roddan, G., Nicol, J., Springer, M., Martin, S., Cameron, B., 1998, "Development of a Standard for the health Hazard Assessment of Mechanical Shock and Repeated Impact in Army Vehicles: Phase 5," Prepared by B.C. Research Inc. for U.S. Army Aeromedical Research laboratory, Fort Rucker AL., Contract Report CR-98-01.
4. DRAFT INTERNATIONAL STANDARD ISO/DIS 2631-5, "Mechanical Vibration and Shock – Evaluation of Human Exposure to Whole-Body Vibration – Part 5: Method for Evaluation of Vibration Containing Multiple Shocks," International Organization for Standardization, 2001. Note: "This document is a draft circulated for comment and approval. It is therefore subject to change and may not be referred to as an International Standard until published as such."
5. Harris, C. H., Piersol, A. G., "Harris' Shock and Vibration Handbook," Fifth Edition, McGraw-Hill, 2002.

ACKNOWLEDGMENTS

The author would like to acknowledge Lorrie Battaglia of Taylor Devices, Inc. for her assistance with this paper.